

IM-2-AF-SF0

Electrical specifications

Winding code : SF0	Symbol	Unit	Field weakening & Water cooling
Continuous torque	T_c	Nm	1480
Continuous current	I_c	A_{rms}	114.4
Stall torque	T_s	Nm	1242
Stall current	I_s	A_{rms}	91.5
Peak torque(for 1sec.)	T_p	Nm	2230
Peak current(for 1sec.)	I_p	A_{rms}	255
Torque constant	K_t	Nm/A_{rms}	14.72
Electrical time constant	T_e	ms	6.7
Resistance (line to line at 25°C)	R_{25}	Ω	0.3
Inductance (line to line)	L_d / L_q	mH	2 / 2.58
Number of poles	2p		66
Back emf constant (line to line)	K_v	$V_{rms}/rad/s$	8.5
Motor constant (at 25°C)	K_m	Nm/\sqrt{W}	21.94
Thermal resistance	R_{th}	K/W	0.018
Thermal sensor			PTC SNM100+SNM130+Pt1000
Max. DC BUS		V_{DC}	750
Inertia of rotor	J	kgm^2	0.694
Thermal time constant	T_{th}	s	120
Max. continuous power dissipation	P_c	W	8245
Max. peak power dissipation	P_p	W	40965
Max. speed(at 600VDC)		rpm	1600
Based speed(at 600VDC)		rpm	351
Rated speed(at 600VDC)		rpm	1600

T-N curve

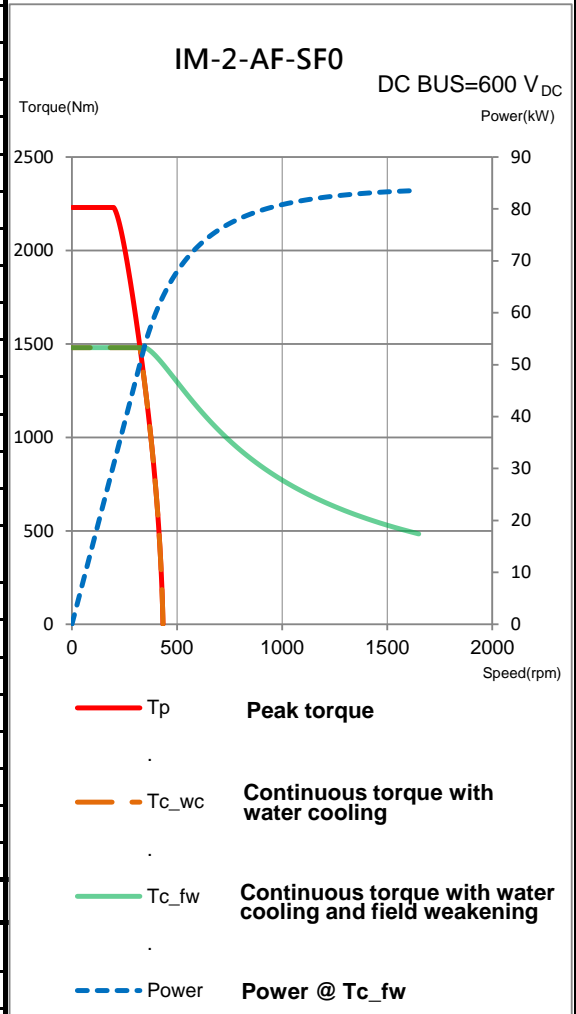

Mechanical specifications

	Symbol	Unit	Field weakening & Water cooling
Mass of rotor	M_r	kg	41.2
Mass of stator	M_s	kg	63.1
Height of stator	H_s	mm	210
Height of rotor	H_r	mm	171
Length of rotor centring fit	H	mm	20
Water temperature difference for P_c	$\Delta\theta$	K	5
Minimum water flow	q	l/min	23.6
Max. pressure drop	Δp	bar	3

Thermal sensor

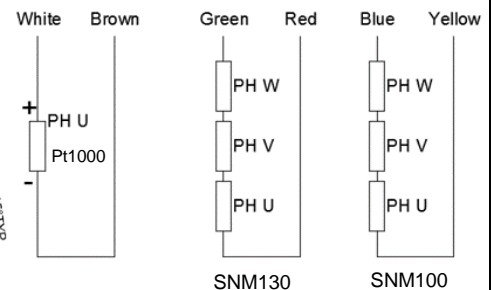
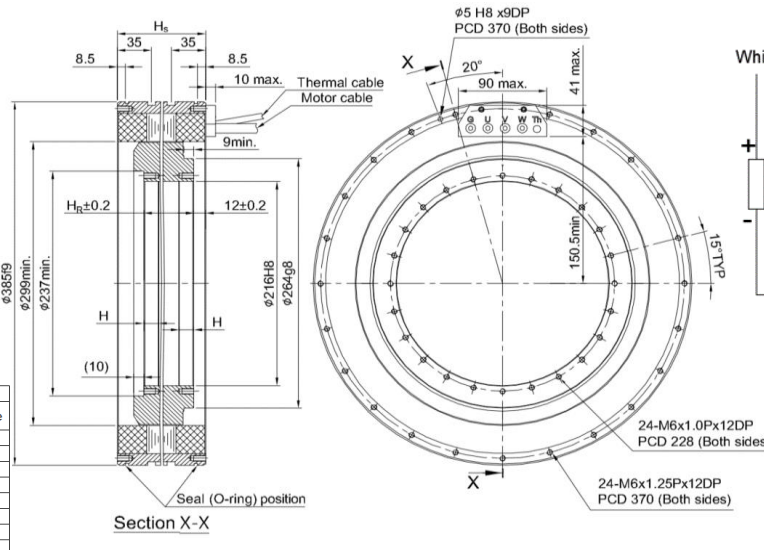

General tolerance mm	
Nominal dimension	Tolerance
~ 6	±0.1
> 6 ~ 30	±0.2
> 30 ~ 120	±0.3
> 120 ~ 300	±0.4
> 300 ~ 600	±0.5
> 600 ~ 1200	±0.8
> 1200 ~ 2400	±1.0
> 2400	±1.5

Motor wire table	
Color or wire no.	Signal
U/L1	PH U
V/L2	PH V
W/L3	PH W
Green/Yellow	GND

Except dimensions, all the specifications in the table are in ±10% of tolerance

Version: 2.00

This drawing is only for reference, detail dimensions please refer to approval drawing.

Date: 2020/10/23